



## Vacation Bible School 2020 3s-Kinder SESSION 4

### JESUS MADE A PROMISE

**Bible Story Passage:** Matthew 28:1-10; 16-20

**What's The Point?:** Jesus will always be with me.

**Focus Verse:** I know that God started a good work in me and He will complete it. Philippians 1:6

After Jesus died and was placed in a tomb, a stone was rolled in front of the tomb to seal it. His friends Mary Magdalene and another woman named Mary went to visit the place where Jesus' body had been taken. (Move feet as if walking slowly; make a sad face, too.)

There was an earthquake and an angel of the Lord came down from heaven. (Shake in your seat for earthquake.)

The angel, who was dressed in white, rolled back the stone that had been placed in front of the tomb and sat on it. (Speak in excited voice.)

The angel told them Jesus is alive! Jesus was going to Galilee to see His disciples (helpers). This was wonderful news. The women were so happy. They hurried to find Jesus' disciples to tell them the good news. (Smile; move feet as if walking quickly.)

Then Jesus met the women and said, "Good morning! Go tell My disciples to leave for Galilee. They will see Me there." The women looked for the disciples and told them the news. (Put hand over eyes as if searching.)

When the disciples heard the women's message, they traveled to the mountain in Galilee where Jesus told them to go. When the disciples saw Jesus, they worshiped Him. (Kneel or bow head as if praying.)

Then Jesus spoke to the men. He said, "Go and tell everyone about me. Teach people to do everything I have told you." Jesus told the disciples that they should tell people everywhere that Jesus is alive. (Spread arms apart, showing 'everywhere'.)

"And remember, I am with you always," Jesus said. (Place both hands on chest.)

### Closing Riddles

- I died and was placed in a tomb. Who am I? (Jesus)
- The two of us went to visit the tomb. Who are we? (the two Marys)
- There was an earthquake and I came down from heaven and rolled away the stone. Who am I? (angel)
- I spoke to the two Marys and then met with the disciples. Who am I? (Jesus)
- Jesus said the disciples should tell us about Jesus. Who are we? (everyone)
- Jesus came to show God's love for us. Who are we? (everyone!)

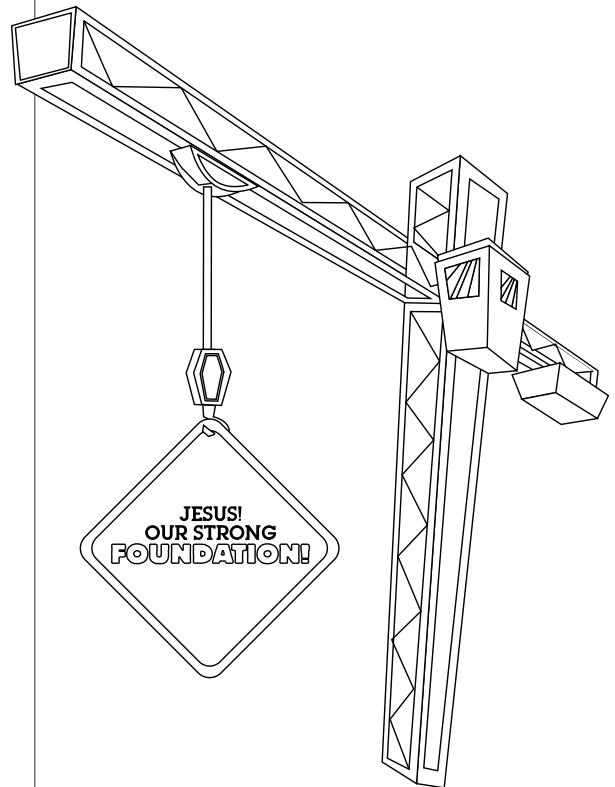



## Vacation Bible School 2020 3's-Kinder SESSION 4

### JESUS MADE A PROMISE

#### INTRODUCTION ACTIVITIES

**Activity:** Complete the “Jesus Made a Promise” Coloring Sheet (in the VBS packet or at [www.pcbc.org/vbs](http://www.pcbc.org/vbs).)

#### GROUP TIME

**Introduce the Bible Story:** Discuss what it means to make a promise. (For preschoolers, you may say a promise is making our actions go along with our words.) Talk about promises your child has made and ways he kept those promises. Today’s story is about a promise Jesus made.

**Tell or watch the Bible Story:** “Jesus Made a Promise.” (You can watch Amy Wiede teach today’s Bible story by going to [www.pcbc.org/vbs](http://www.pcbc.org/vbs).) If you choose to teach the Bible story, have your Bible open to the day’s passage. Be familiar enough with the story that you can tell it, and not just read it! (The Bible story is in the VBS packet or at [www.pcbc.org/vbs](http://www.pcbc.org/vbs).)

**Review the Bible story:** Show the Bible Story picture. Encourage the children to tell what they remember about the Bible story. Ask review questions:

- How did the women feel as they walked toward the tomb? (sad)
- What happened as they walked to the tomb? (earthquake)
- What did the angel tell the women? (“Jesus is alive”)
- What did the women do after they heard the message? (hurried to find the disciples)
- What did the disciples do when they saw Jesus on the mountain? (worshipped Him)
- What promise did Jesus make? (“I am always with you”)

**Pray together:** Pray. Thank God for Jesus. Thank God that Jesus is always with us.

#### BIBLE VERSE MEMORY

**Bible Verse Song** to the tune of “Row, Row, Row Your Boat” Sing this song with children each day to help them memorize our verse. (Included in VBS packet or at [www.pcbc.org/vbs](http://www.pcbc.org/vbs).)

#### BIBLE LEARNING ACTIVITIES

**Activity 1:** Empty Tomb Craft: (Supplies and instructions are in the VBS kit. If you don’t have a kit, here is a link to an alternate empty tomb craft: [Empty tomb craft](#))

**Activity 2:** Recall the Bible Story: Throughout the week, use activities your child enjoys to review the daily Bible story and Bible verse. (See list of suggested activities from the VBS Activity Idea sheet, either in packet or at [www.pcbc.org/vbs](http://www.pcbc.org/vbs).)

#### CLOSING RALLY

(Go to [www.pcbc.org/vbs](http://www.pcbc.org/vbs) to watch this session’s Worship Rally.) After the rally time, use the closing riddles (found on the Bible Story sheet in the VBS packet or at [www.pcbc.org/vbs](http://www.pcbc.org/vbs).)

